

OPzV2-350(2V350Ah)



Ritar OPzV series is Valve Regulated Lead Acid battery that adopts immobilized GEL and Tubular Plate technology to offer high reliability and performance. The Battery is designed and manufactured according to DIN standards and with die-casting positive grid and patented formula of active material OPzV series exceeds DIN standard values with more than 20 years floating design life at 25 °C ,and It is the best solution for cyclic use under extreme operating conditions.



Specification

Cells Per Unit	1
Voltage Per Unit	2
Nominal Capacity	350Ah@10hr-rate to 1.80V per cell @25°C
Weight	Approx. 27.5 Kg (Tolerance±2%)
Internal Resistance	Approx. 0.80 mΩ
Terminal	F10(M8)
Max. Discharge Current	1500A (5 sec)
Design Life	20 years (floating charge)
Maximum Charging Current	70.0 A
Reference Capacity	C24 393AH C48 437AH C72 440AH C100 448AH C120 457AH C240 465AH
Float Charging Voltage	2.25 V~2.30 V @ 25°C Temperature Compensation: -3mV/°C/Cell
Cycle Use Voltage	2.35 V~2.40 V @ 25°C Temperature Compensation: -4mV/°C/Cell
Operating Temperature Range	Discharge: -40°C~60°C Charge: -20°C~50°C Storage: -40°C~60°C
Normal Operating Temperature Range	25°C±5°C
Self Discharge	RITAR Valve Regulated Lead Acid (VRLA) batteries can be stored for up to 6 months at 25°C and then recharging is recommended. Monthly Self-discharge ratio is less than 2% at 25°C. Please charged batteries before using.
Container Material	A.B.S. UL94-HB, UL94-V0 Optional.

Dimensions

Unit: mm

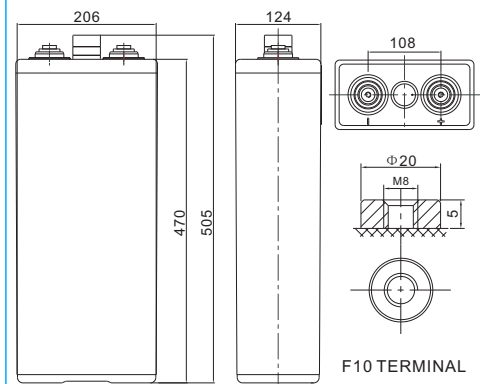

Length	124±1mm (4.88 inches)
Width	206±1mm (8.11 inches)
Height	470±1mm (18.5 inches)
Total Height	505±1mm (19.9 inches)
Torque Value	10~12 N*m

Constant Current Discharge Characteristics : A(25°C)

F.V/ Time	30min	1h	2h	3h	4h	5h	6h	8h	10h	20h
1.90V	172.2	136.5	96.25	73.01	59.85	51.73	46.55	36.33	31.15	16.35
1.87V	192.5	150.5	103.3	77.42	63.18	54.39	49.35	38.02	32.55	17.09
1.83V	220.5	168.0	112.0	82.50	66.50	56.77	51.10	39.72	33.95	17.82
1.80V	245.0	182.0	116.2	84.88	67.83	58.10	52.50	40.74	35.00	18.38
1.75V	273.0	195.0	121.5	88.27	68.95	59.50	53.55	41.42	35.70	18.74
1.70V	301.0	201.3	125.0	89.99	70.16	60.20	54.25	41.76	36.05	18.93
1.65V	310.5	213.9	129.2	92.40	71.16	60.90	54.95	42.10	36.40	19.11
1.60V	323.8	221.2	134.1	96.25	73.15	61.95	55.65	42.44	36.75	19.29

Constant Power Discharge Characteristics : WPC(25°C)

F.V/ Time	30min	1h	2h	3h	4h	5h	6h	8h	10h	20h
1.90V	329.6	262.1	186.1	141.4	117.1	101.9	92.05	72.65	63.49	33.33
1.87V	362.7	284.6	197.3	148.1	123.5	106.8	97.30	75.71	66.20	34.76
1.83V	406.3	310.2	210.0	155.8	129.4	111.0	100.5	78.42	68.58	36.00
1.80V	443.9	331.0	217.0	159.4	131.9	113.4	102.9	80.12	70.28	36.90
1.75V	481.5	345.8	224.1	164.3	133.7	116.2	104.7	81.14	71.30	37.43
1.70V	516.4	349.3	229.7	167.1	135.8	117.3	105.7	81.82	71.97	37.79
1.65V	525.2	364.8	236.0	170.6	137.5	118.3	106.8	82.50	72.31	37.96
1.60V	531.5	376.0	241.7	176.2	141.1	119.4	107.5	82.84	72.65	38.14

(Note) The above characteristics data are average values obtained within three charge/discharge cycle not the minimum values.

OPzV2-350(2V350Ah)



Discharge Characteristics Curve

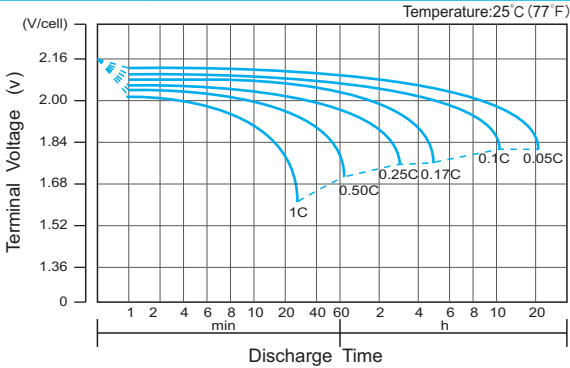

Charge Characteristic Curve for Cycle Use(IU)

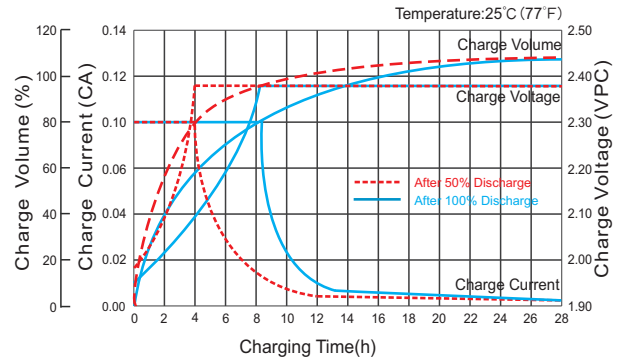

Cycle Life in Relation to Depth of Discharge

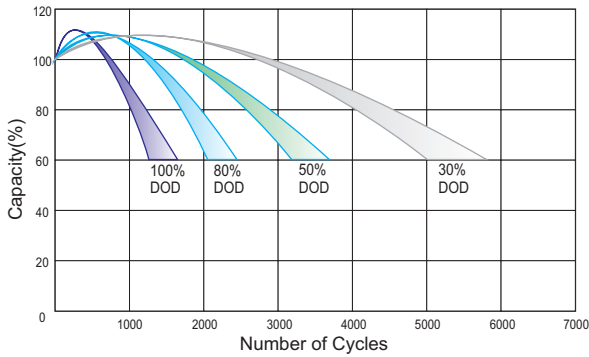

Relationship Between Charging Voltage and Temperature

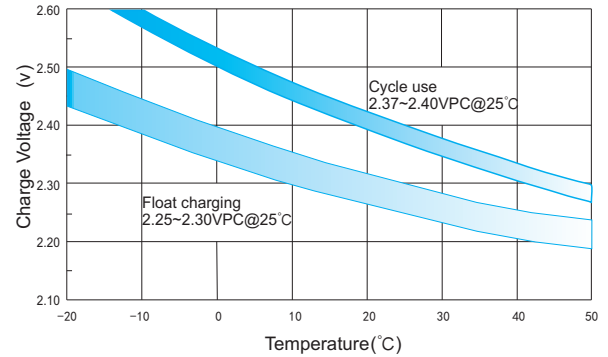

Temperature Effects on Capacity

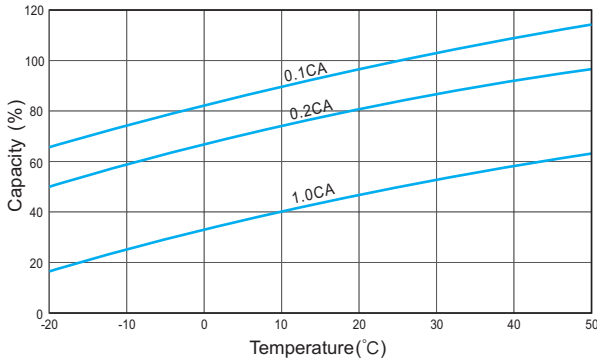

Storage Characteristics

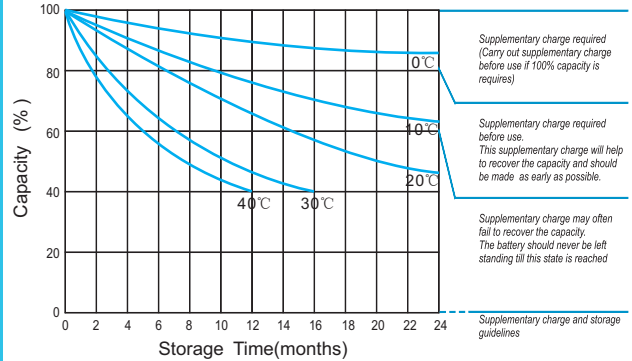

Effect of Temperature on Long Term Life

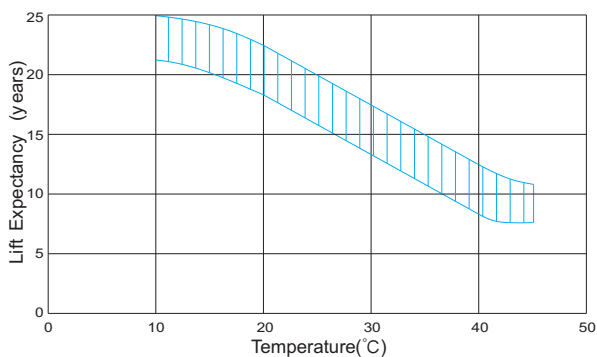

Relationship of OCV And State of Charge(20°C)

